

CWDM 8 Point to Point

SML2000 Chassis

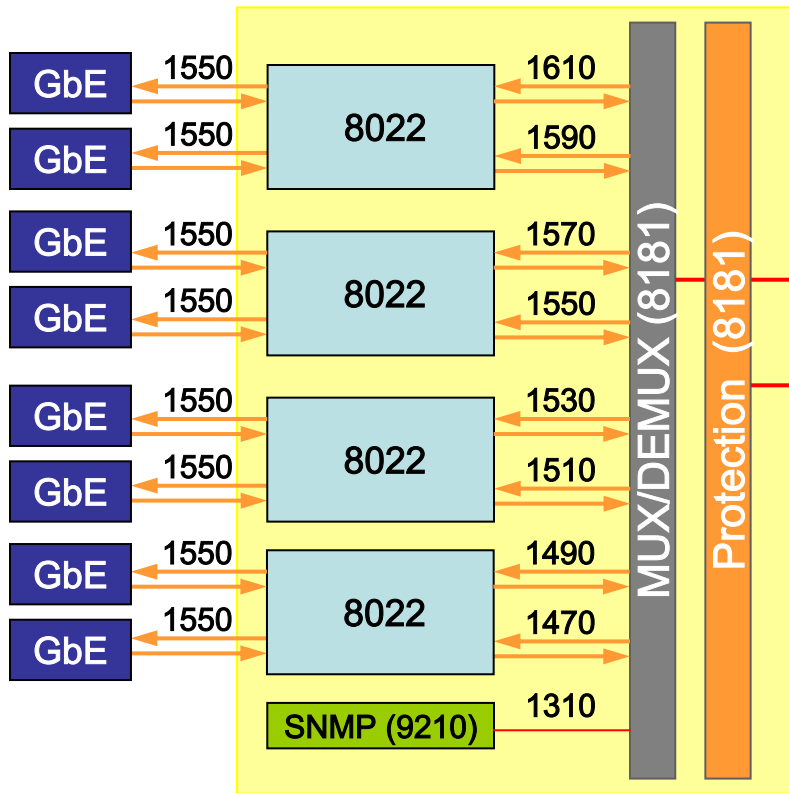

40km~80km

SML2000 Chassis

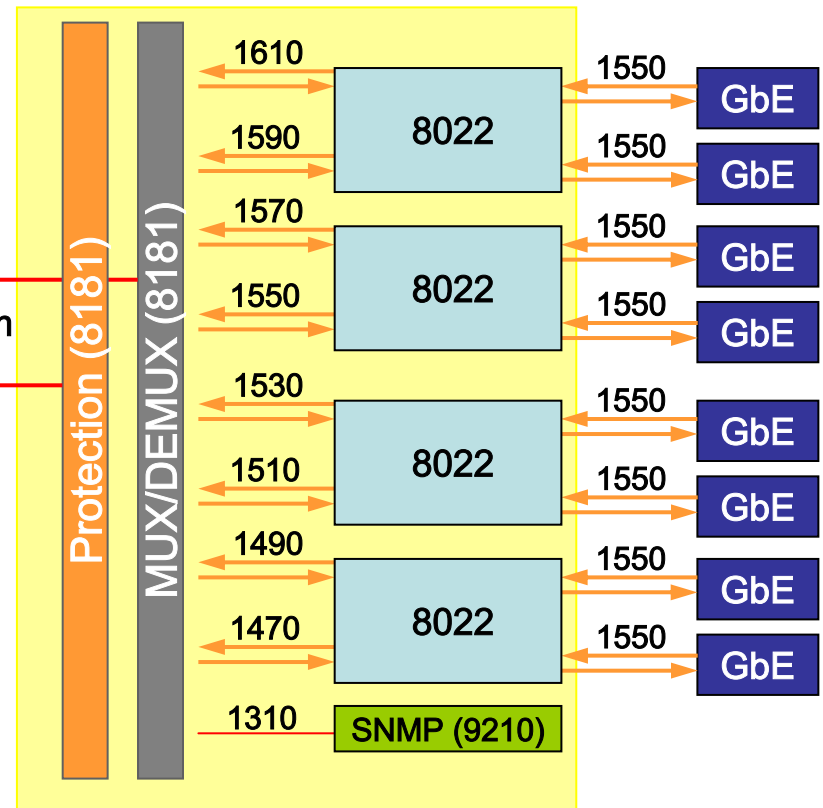

Point to Point Equipments Requirements

Chassis :

- 9021-----SML2000 Chassis ----- x 2 pcs
- 9120-----Chassis Power DC or AC ----- x 4 pcs
- 9210-----SNMP Card ----- x 2 pcs

Line Card Modules:

- 8022-----2.5G 2-channel Transponder card x 8 pcs
- 8181-----8+1 Mux/Demux card x 2 pcs
- 8210-----Optical Protection card x 2

SPF Transceiver :

- SFS-9040-L55-----1.25G (1310nm or 1550nm) SFP x 16 pcs
- SFP-9040-CXX----- CWDM 1.25G (1470 ~ 1610nm) SFP x 16 pcs